

# LR(1) for

$$E \leftarrow T \mid$$
$$T \leftarrow F$$
$$T \leftarrow T * F$$
$$F \leftarrow i$$
$$F \leftarrow ( T )$$

Bill McKeeman

Dartmouth

April 18, 2008

$E \leftarrow T \mid$

$T \leftarrow F$

$T \leftarrow T * F$

$F \leftarrow i$

$F \leftarrow ( T )$

a simple  
expression cfg

end-of-file symbol



$E \leftarrow \cdot T \mid$



*LR start state*

$E \leftarrow T \mid$

$T \leftarrow F$

$T \leftarrow T * F$

$F \leftarrow i$

$F \leftarrow ( T )$

$E \leftarrow T \mid$	
$T \leftarrow F \mid$	$\mid$
$T \leftarrow T * F \mid$	$\mid$

$E \leftarrow T \mid$   
 $T \leftarrow F$   
 $T \leftarrow T * F$   
 $F \leftarrow i$   
 $F \leftarrow (T)$

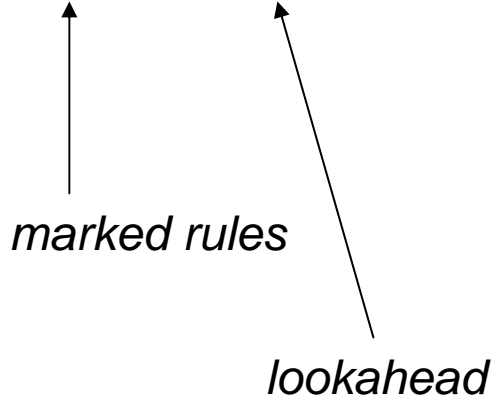

*closure for T*

kernel in red

closure in green

$E \leftarrow \square T \vdash$	
$T \leftarrow \square F \vdash$	$\vdash$
$T \leftarrow \square T * F \vdash$	$\vdash$
$F \leftarrow \square i \vdash$	$\vdash$
$F \leftarrow \square (T) \vdash$	$\vdash$

$E \leftarrow T \vdash$

$T \leftarrow F$

$T \leftarrow T * F$

$F \leftarrow i$

$F \leftarrow (T)$

*closure for F*

$E \leftarrow T \mid$	
$T \leftarrow F \mid$	
$T \leftarrow T * F \mid$	
$F \leftarrow i \mid$	
$F \leftarrow (T) \mid$	
$T \leftarrow F$	*
$T \leftarrow T * F$	*

$E \leftarrow T \mid$

$T \leftarrow F$

$T \leftarrow T * F$

$F \leftarrow i$

$F \leftarrow (T)$

*another closure for T*

$E \leftarrow T$		
$T \leftarrow F$		
$T \leftarrow T * F$		
$F \leftarrow i$		
$F \leftarrow (T)$		
$T \leftarrow F$		*
$T \leftarrow T * F$		*
$F \leftarrow i$		*
$F \leftarrow (T)$		*

$E \leftarrow T$   
 $T \leftarrow F$   
 $T \leftarrow T * F$   
 $F \leftarrow i$   
 $F \leftarrow (T)$

*another closure for F*

$E \leftarrow T \mid$	
$T \leftarrow F$	$\mid^*$
$T \leftarrow T * F$	$\mid^*$
$F \leftarrow i$	$\mid^*$
$F \leftarrow (T)$	$\mid^*$

$E \leftarrow T \mid$

$T \leftarrow F$

$T \leftarrow T * F$

$F \leftarrow i$

$F \leftarrow (T)$

*merge lookaheads*

*closure complete*

$E \leftarrow \square T \mid$	
$T \leftarrow \square F$	$\mid^*$
$T \leftarrow \square T * F$	$\mid^*$
$F \leftarrow \square i$	$\mid^*$
$F \leftarrow \square (T)$	$\mid^*$

$E \leftarrow T \square \mid$	
$T \leftarrow T \square * F$	$\mid^*$

$E \leftarrow T \mid$   
 $T \leftarrow F$   
 $T \leftarrow T * F$   
 $F \leftarrow i$   
 $F \leftarrow (T)$



*shift T*

*new kernel*

$E \leftarrow \square T \mid$	
$T \leftarrow \square F$	$\mid^*$
$T \leftarrow \square T * F$	$\mid^*$
$F \leftarrow \square i$	$\mid^*$
$F \leftarrow \square (T)$	$\mid^*$

$E \leftarrow T \square \mid$	
$T \leftarrow T \square * F$	$\mid^*$

$T \leftarrow F \square$	$\mid^*$
--------------------------	----------

$E \leftarrow T \mid$   
 $T \leftarrow F$   
 $T \leftarrow T * F$   
 $F \leftarrow i$   
 $F \leftarrow (T)$

*shift F*

*another new kernel*

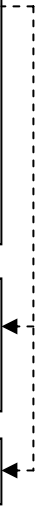

$E \leftarrow \square T \mid$	
$T \leftarrow \square F$	$\mid^*$
$T \leftarrow \square T * F$	$\mid^*$
$F \leftarrow \square i$	$\mid^*$
$F \leftarrow \square (T)$	$\mid^*$

$E \leftarrow T \mid$   
 $T \leftarrow F$   
 $T \leftarrow T * F$   
 $F \leftarrow i$   
 $F \leftarrow (T)$

$E \leftarrow T \square \mid$	
$T \leftarrow T \square * F$	$\mid^*$

$T \leftarrow F \square$	$\mid^*$
--------------------------	----------

$F \leftarrow i \square$	$\mid^*$
--------------------------	----------

*shift i*

*another new kernel*

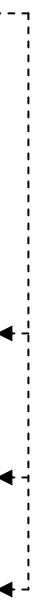

1

$E \leftarrow \square T \mid$	
$T \leftarrow \square F$	$\mid^*$
$T \leftarrow \square T * F$	$\mid^*$
$F \leftarrow \square i$	$\mid^*$
$F \leftarrow \square ( T )$	$\mid^*$

$E \leftarrow T \mid$   
 $T \leftarrow F$   
 $T \leftarrow T * F$   
 $F \leftarrow i$   
 $F \leftarrow ( T )$

$E \leftarrow T \square \mid$	
$T \leftarrow T \square * F$	$\mid^*$

*finish state 1*

$T \leftarrow F \square$	$\mid^*$
--------------------------	----------

*shift (*

$F \leftarrow i \square$	$\mid^*$
--------------------------	----------

*another new kernel*

$F \leftarrow ( \square T )$	$\mid^*$
------------------------------	----------



1

$E \leftarrow \square T \mid$	
$T \leftarrow \square F$	$\mid^*$
$T \leftarrow \square T * F$	$\mid^*$
$F \leftarrow \square i$	$\mid^*$
$F \leftarrow \square (T)$	$\mid^*$

$E \leftarrow T \square \mid$	
$T \leftarrow T \square * F$	$\mid^*$

$T \leftarrow F \square$	$\mid^*$
--------------------------	----------

$F \leftarrow i \square$	$\mid^*$
--------------------------	----------

$F \leftarrow (\square T)$	$\mid^*$
$T \leftarrow \square F$	$)^*$
$T \leftarrow \square T * F$	$)^*$
$F \leftarrow \square i$	$)^*$
$F \leftarrow \square (T)$	$)^*$

$E \leftarrow T \mid$

$T \leftarrow F$

$T \leftarrow T * F$

$F \leftarrow i$

$F \leftarrow (T)$

*closure*

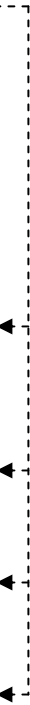

1

$E \leftarrow \square T \mid$	
$T \leftarrow \square F$	$\mid^*$
$T \leftarrow \square T * F$	$\mid^*$
$F \leftarrow \square i$	$\mid^*$
$F \leftarrow \square ( T )$	$\mid^*$

$E \leftarrow T \square \mid$	
$T \leftarrow T \square * F$	$\mid^*$

$T \leftarrow F \square$	$\mid^*$
--------------------------	----------

$F \leftarrow i \square$	$\mid^*$
--------------------------	----------

$F \leftarrow ( \square T )$	$\mid^*$
$T \leftarrow \square F$	$)^*$
$T \leftarrow \square T * F$	$)^*$
$F \leftarrow \square i$	$)^*$
$F \leftarrow \square ( T )$	$)^*$

$E \leftarrow T \mid \square$	
-------------------------------	--

$E \leftarrow T \mid$

$T \leftarrow F$

$T \leftarrow T * F$

$F \leftarrow i$

$F \leftarrow ( T )$

*shift  $\mid$  (final LR state)*

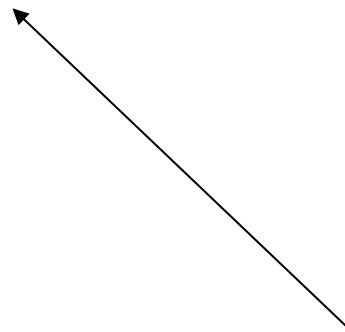

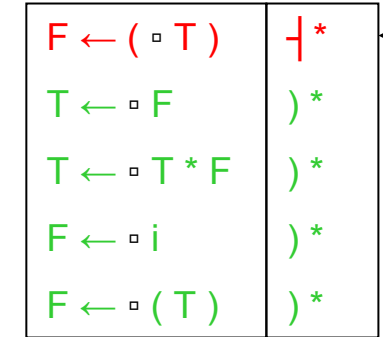
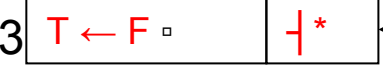
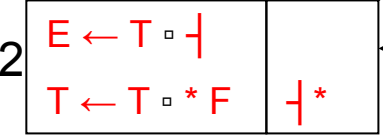
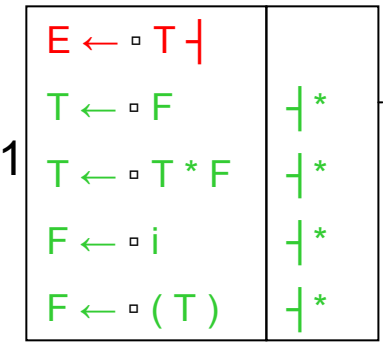

$E \leftarrow T \mid$   
 $T \leftarrow F$   
 $T \leftarrow T^* F$   
 $F \leftarrow i$   
 $F \leftarrow (T)$

*shift \**

*finish states 2,3,4*

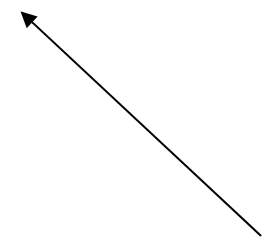

1

$E \leftarrow \square T \mid$	
$T \leftarrow \square F$	$\mid^*$
$T \leftarrow \square T^* F$	$\mid^*$
$F \leftarrow \square i$	$\mid^*$
$F \leftarrow \square (T)$	$\mid^*$

2

$E \leftarrow T \square \mid$	
$T \leftarrow T \square ^* F$	$\mid^*$

3

$T \leftarrow F \square$	$\mid^*$
--------------------------	----------

4

$F \leftarrow i \square$	$\mid^*$
--------------------------	----------

$F \leftarrow (\square T)$	$\mid^*$
$T \leftarrow \square F$	$)^*$
$T \leftarrow \square T^* F$	$)^*$
$F \leftarrow \square i$	$)^*$
$F \leftarrow \square (T)$	$)^*$

$E \leftarrow T \mid \square$	
-------------------------------	--

$T \leftarrow T^* \square F$	$\mid^*$
$F \leftarrow \square i$	$\mid^*$
$F \leftarrow \square (T)$	$\mid^*$

- $E \leftarrow T \mid$
- $T \leftarrow F$
- $T \leftarrow T^* F$
- $F \leftarrow i$
- $F \leftarrow (T)$

*closure*



1

$E \leftarrow \square T \mid$	
$T \leftarrow \square F$	$\mid^*$
$T \leftarrow \square T * F$	$\mid^*$
$F \leftarrow \square i$	$\mid^*$
$F \leftarrow \square (T)$	$\mid^*$

2

$E \leftarrow T \square \mid$	
$T \leftarrow T \square * F$	$\mid^*$

3

$T \leftarrow F \square$	$\mid^*$
--------------------------	----------

4

$F \leftarrow i \square$	$\mid^*$
--------------------------	----------

$F \leftarrow (\square T)$	$\mid^*$
$T \leftarrow \square F$	$)^*$
$T \leftarrow \square T * F$	$)^*$
$F \leftarrow \square i$	$)^*$
$F \leftarrow \square (T)$	$)^*$

$E \leftarrow T \mid \square$	
-------------------------------	--

$T \leftarrow T * \square F$	$\mid^*$
$F \leftarrow \square i$	$\mid^*$
$F \leftarrow \square (T)$	$\mid^*$

$F \leftarrow (T \square)$	$\mid^*$
$T \leftarrow T \square * F$	$)^*$

$E \leftarrow T \mid$   
 $T \leftarrow F$   
 $T \leftarrow T * F$   
 $F \leftarrow i$   
 $F \leftarrow (T)$

*shift T*



1

$E \leftarrow \square T \mid$	
$T \leftarrow \square F$	$\mid^*$
$T \leftarrow \square T^* F$	$\mid^*$
$F \leftarrow \square i$	$\mid^*$
$F \leftarrow \square (T)$	$\mid^*$

2

$E \leftarrow T \square \mid$	
$T \leftarrow T \square^* F$	$\mid^*$

3

$T \leftarrow F \square$	$\mid^*$
--------------------------	----------

4

$F \leftarrow i \square$	$\mid^*$
--------------------------	----------

$F \leftarrow (\square T)$	$\mid^*$
$T \leftarrow \square F$	$)^*$
$T \leftarrow \square T^* F$	$)^*$
$F \leftarrow \square i$	$)^*$
$F \leftarrow \square (T)$	$)^*$

$E \leftarrow T \mid \square$	
-------------------------------	--

$T \leftarrow T^* \square F$	$\mid^*$
$F \leftarrow \square i$	$\mid^*$
$F \leftarrow \square (T)$	$\mid^*$

$F \leftarrow (T \square)$	$\mid^*$
$T \leftarrow T \square^* F$	$)^*$

$T \leftarrow F \square$	$)^*$
--------------------------	-------

$E \leftarrow T \mid$   
 $T \leftarrow F$   
 $T \leftarrow T^* F$   
 $F \leftarrow i$   
 $F \leftarrow (T)$

*shift F*

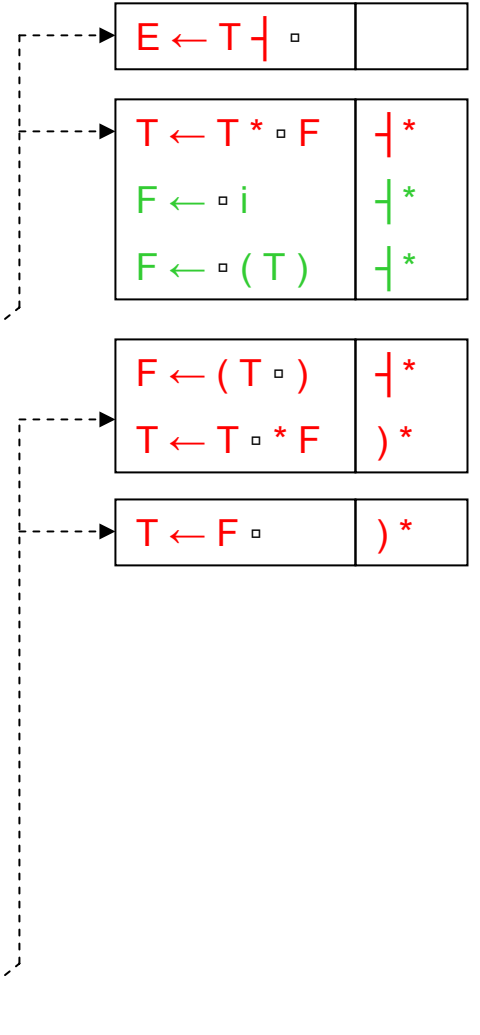

$E \leftarrow \square T \mid$	
$T \leftarrow \square F$	$\mid^*$
$T \leftarrow \square T^* F$	$\mid^*$
$F \leftarrow \square i$	$\mid^*$
$F \leftarrow \square (T)$	$\mid^*$

$E \leftarrow T \square \mid$	
$T \leftarrow T \square^* F$	$\mid^*$

$T \leftarrow F \square$	$\mid^*$
--------------------------	----------

$F \leftarrow i \square$	$\mid^*$
--------------------------	----------

$F \leftarrow (\square T)$	$\mid^*$
$T \leftarrow \square F$	$)^*$
$T \leftarrow \square T^* F$	$)^*$
$F \leftarrow \square i$	$)^*$
$F \leftarrow \square (T)$	$)^*$

$E \leftarrow T \mid \square$	
-------------------------------	--

$T \leftarrow T^* \square F$	$\mid^*$
$F \leftarrow \square i$	$\mid^*$
$F \leftarrow \square (T)$	$\mid^*$

$F \leftarrow (T \square)$	$\mid^*$
$T \leftarrow T \square^* F$	$)^*$

$T \leftarrow F \square$	$)^*$
--------------------------	-------

$F \leftarrow i \square$	$)^*$
--------------------------	-------

$E \leftarrow T \mid$   
 $T \leftarrow F$   
 $T \leftarrow T^* F$   
 $F \leftarrow i$   
 $F \leftarrow (T)$

*shift i*

1

2

3

4

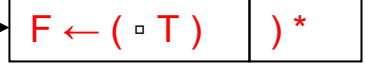
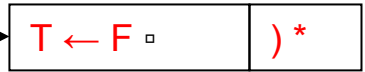
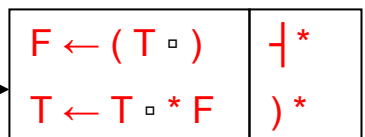
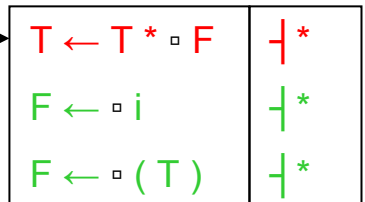
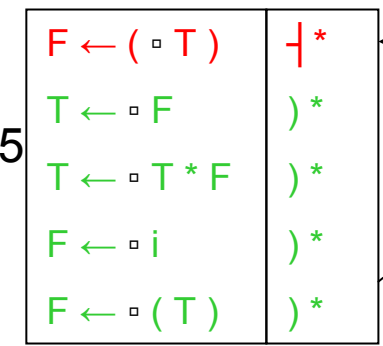
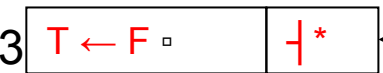
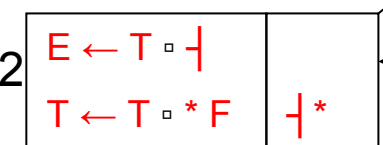
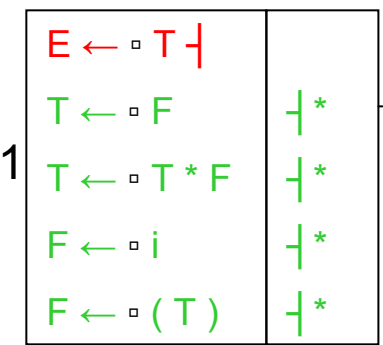

$E \leftarrow T \mid$   
 $T \leftarrow F$   
 $T \leftarrow T^* F$   
 $F \leftarrow i$   
 $F \leftarrow (T)$

← *shift (*

*finish state 5*

1

$E \leftarrow \square T \mid$	
$T \leftarrow \square F$	$\mid^*$
$T \leftarrow \square T^* F$	$\mid^*$
$F \leftarrow \square i$	$\mid^*$
$F \leftarrow \square (T)$	$\mid^*$

2

$E \leftarrow T \square \mid$	
$T \leftarrow T \square^* F$	$\mid^*$

3

$T \leftarrow F \square$	$\mid^*$
--------------------------	----------

4

$F \leftarrow i \square$	$\mid^*$
--------------------------	----------

5

$F \leftarrow (\square T)$	$\mid^*$
$T \leftarrow \square F$	$)^*$
$T \leftarrow \square T^* F$	$)^*$
$F \leftarrow \square i$	$)^*$
$F \leftarrow \square (T)$	$)^*$

$E \leftarrow T \mid \square$	
-------------------------------	--

$T \leftarrow T^* \square F$	$\mid^*$
$F \leftarrow \square i$	$\mid^*$
$F \leftarrow \square (T)$	$\mid^*$

$F \leftarrow (T \square)$	$\mid^*$
$T \leftarrow T \square^* F$	$)^*$

$T \leftarrow F \square$	$)^*$
--------------------------	-------

$F \leftarrow i \square$	$)^*$
--------------------------	-------

$F \leftarrow (\square T)$	$)^*$
$T \leftarrow \square F$	$)^*$
$T \leftarrow \square T^* F$	$)^*$
$F \leftarrow \square i$	$)^*$
$F \leftarrow \square (T)$	$)^*$

- $E \leftarrow T \mid$
- $T \leftarrow F$
- $T \leftarrow T^* F$
- $F \leftarrow i$
- $F \leftarrow (T)$

*closure* →

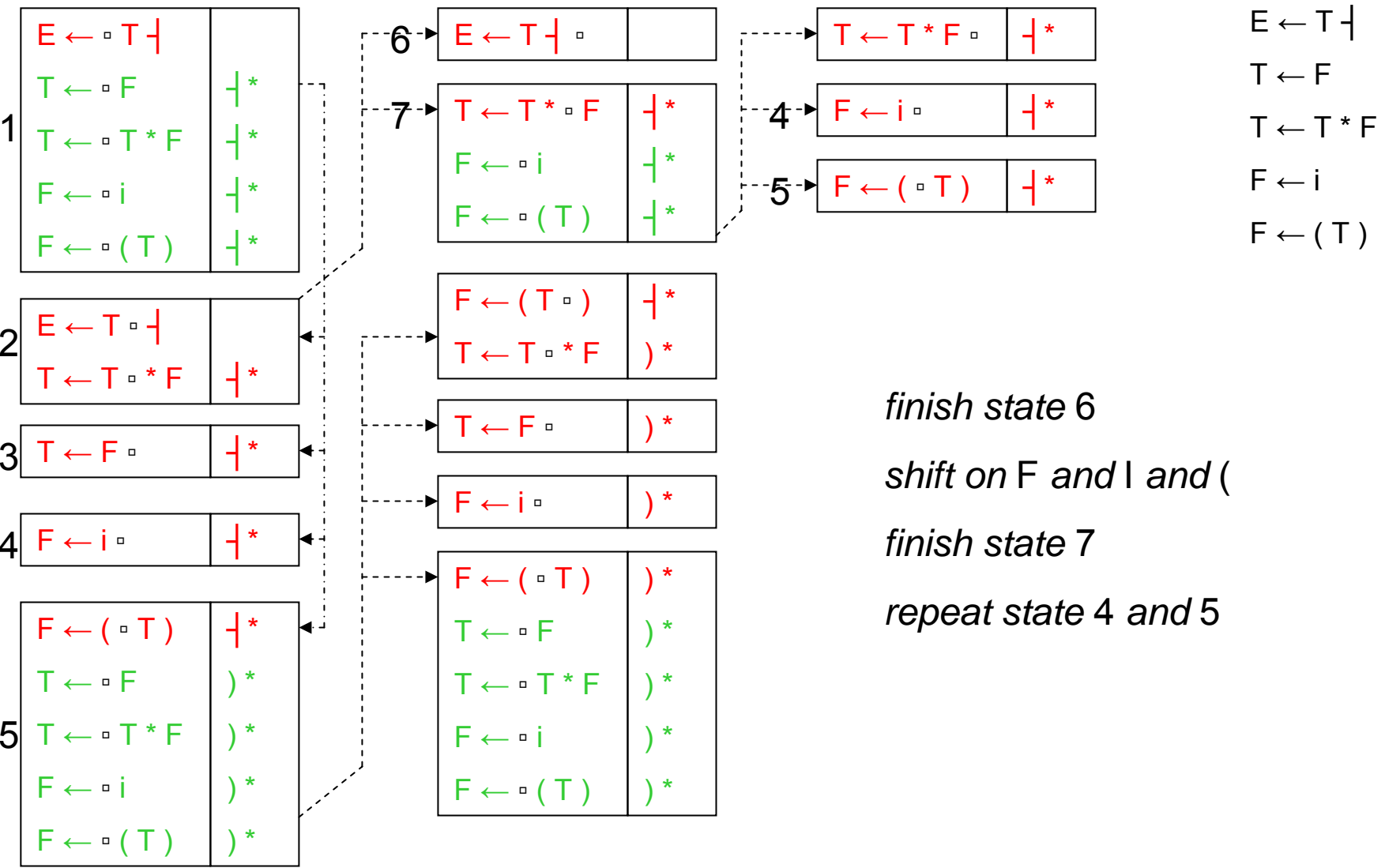

*finish state 6*  
*shift on F and I and (*  
*finish state 7*  
*repeat state 4 and 5*





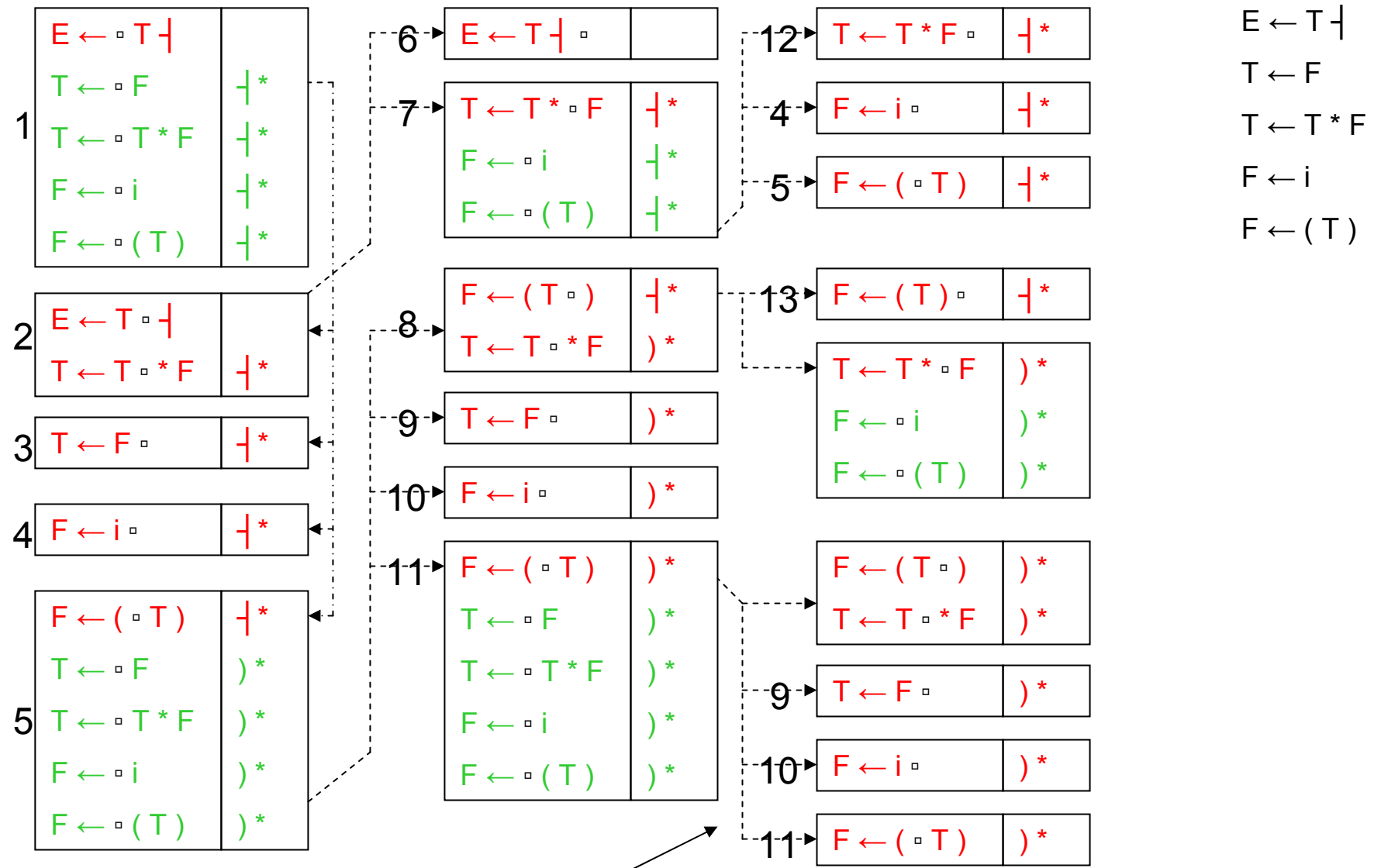

shift on T and F and i and (  
 finish state 11, repeat states 9,10,11, finish states 12,13



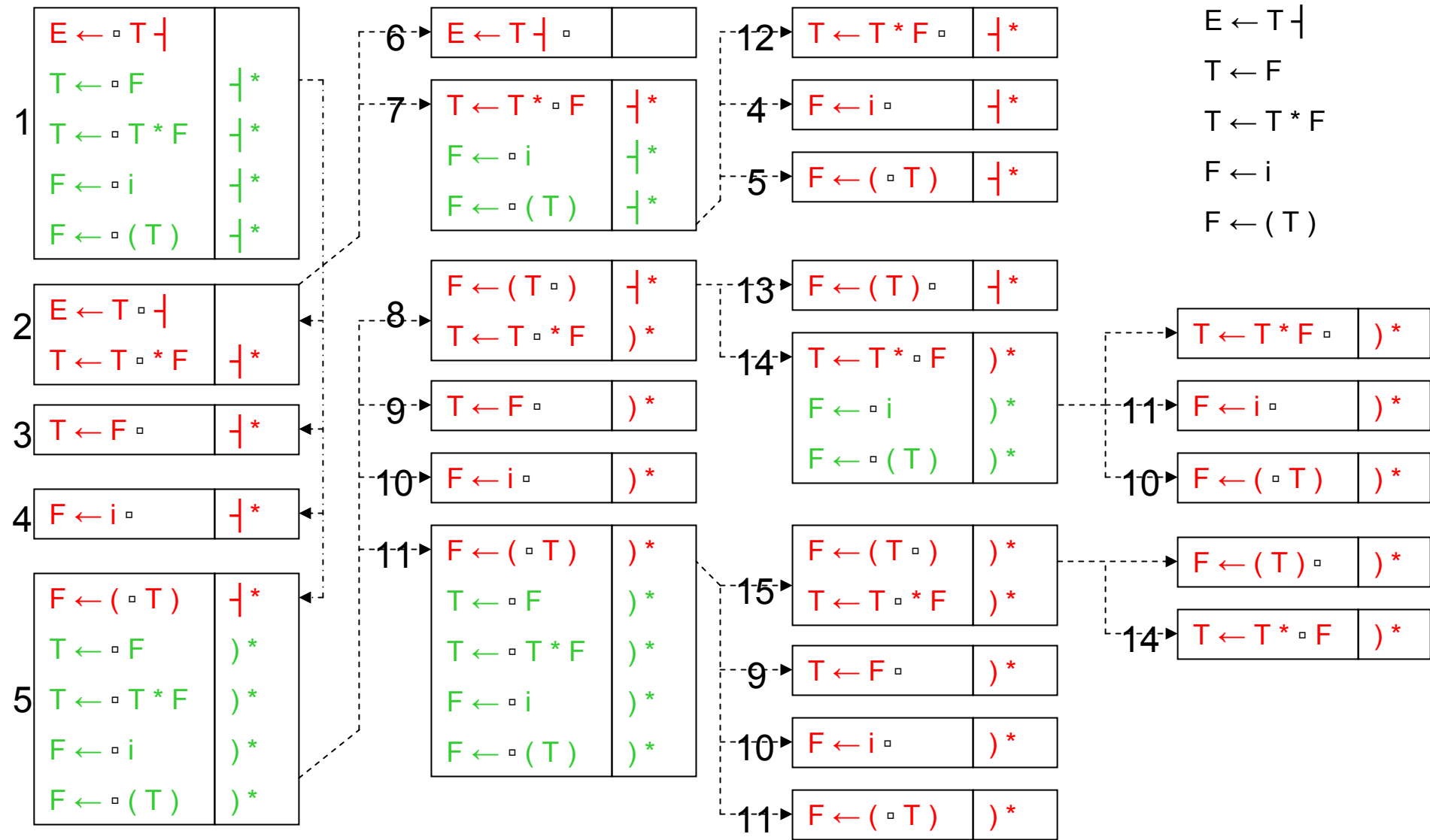

*shift ) and \*, finish state 15, repeat state 14*

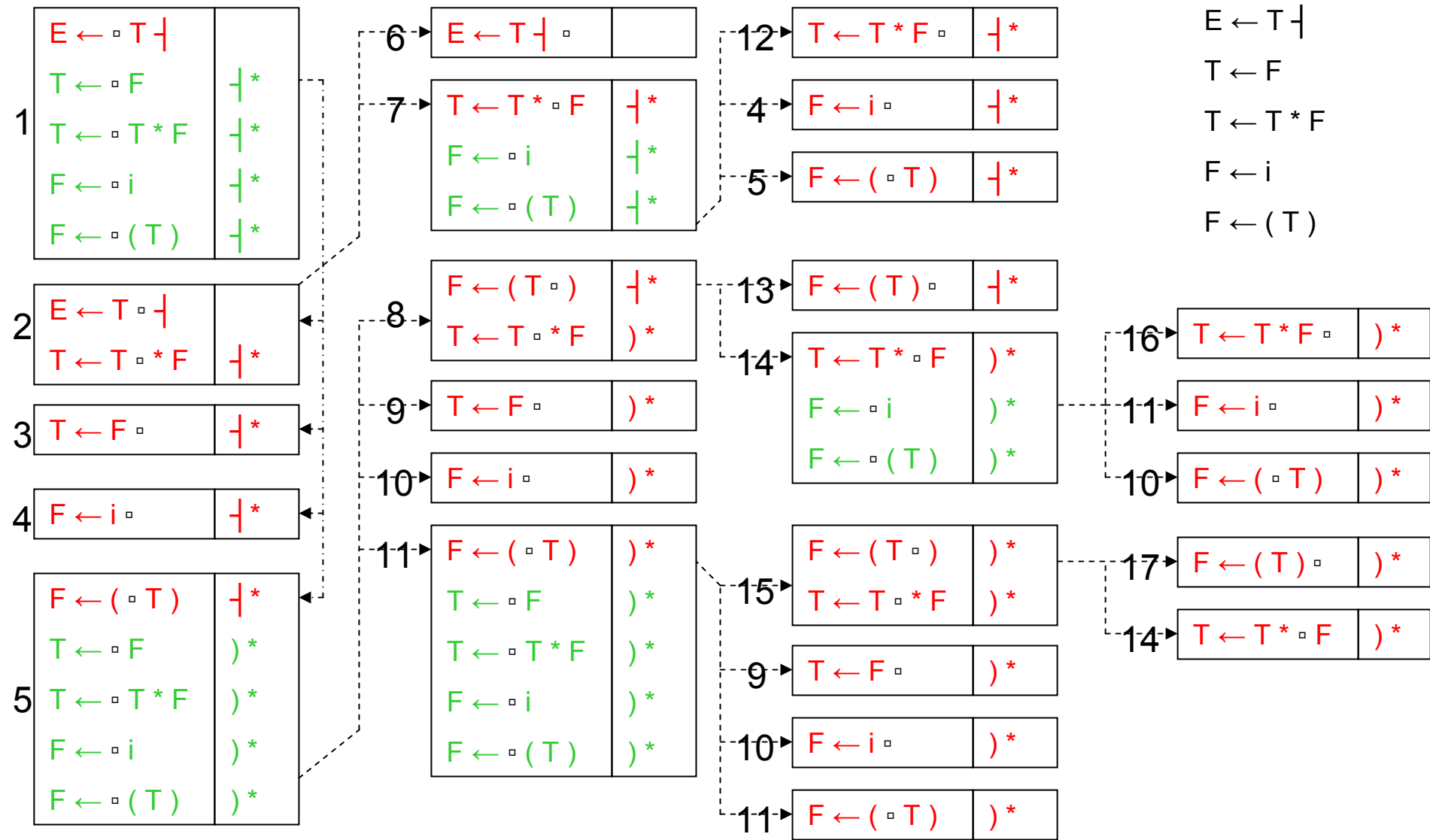

*finish states 16,17*

symbols

# The LR Matrix

stack

input

states

	E	T	F		i	*	(	)
1		2	3		4		5	
2				6		7		
3				-2		-2		
4				-4		-4		
5		8	9		10		11	
6	-1	-1	-1	-1	-1	-1	-1	-1
7			12		4		5	
8			14					13
9						-2		-2
10						-4		-4
11		15	9		10		11	
12				-3		-3		
13				-5		-5		
14			16		11		10	
15						14		17
16						-3		-3
17						-5		-5

-1:  $E \leftarrow T |$

-2:  $T \leftarrow F$

-3:  $T \leftarrow T * F$

-4:  $F \leftarrow i$

-5:  $F \leftarrow ( T )$

1

i \* i |

1 i<sub>4</sub>

\* i |

1 F

\* i |

1 F<sub>3</sub>

\* i |

1 T

\* i |

1 T<sub>2</sub>

\* i |

1 T<sub>2</sub>\*<sub>7</sub>

i |

1 T<sub>2</sub>\*<sub>7</sub>i<sub>4</sub>

|

1 T<sub>2</sub>\*<sub>7</sub>F

|

1 T<sub>2</sub>\*<sub>7</sub>F<sub>12</sub>

|

1 T

|

1 T<sub>2</sub>

|

1 T<sub>2</sub>|<sub>6</sub>

E