

The Science of Insecurity

Len Sassaman
Meredith L. Patterson
Sergey Bratus

Tribute to Len Sassaman

- Anonymity/privacy researcher, cypherpunk
- Moved to language-theoretic security in 2009
- Because the future of an open Internet depends on smoothing out the attack surface



1980 - 2011

Insecurity is the “new normal”

- “Treat all systems as compromised”
 - “There's no such thing as ‘secure’ any more.” -- Deborah Plunkett, NSA Information Assurance Directorate
- “Long weeks to short months before a security meltdown” – Brian Snow, in December 2010
 - “are we there yet?” You bet we are, unless one agrees to view LulzSec as “APT”/nation state

Not for lack of trying

- Various “trustworthy computing” initiatives
- Lots of “secure coding” books
- Mounds of academic publications
- New hacker-developed testing methods: fuzzing, RE-backed binary analysis ...
- Yet software still sucks!
- And hardware – we don’t even know how much it sucks (no tools to poke its attack surface -- yet)

There must be something we are doing wrong

- Science to engineers: some problems are **not solvable**, do not set yourself up to solve them

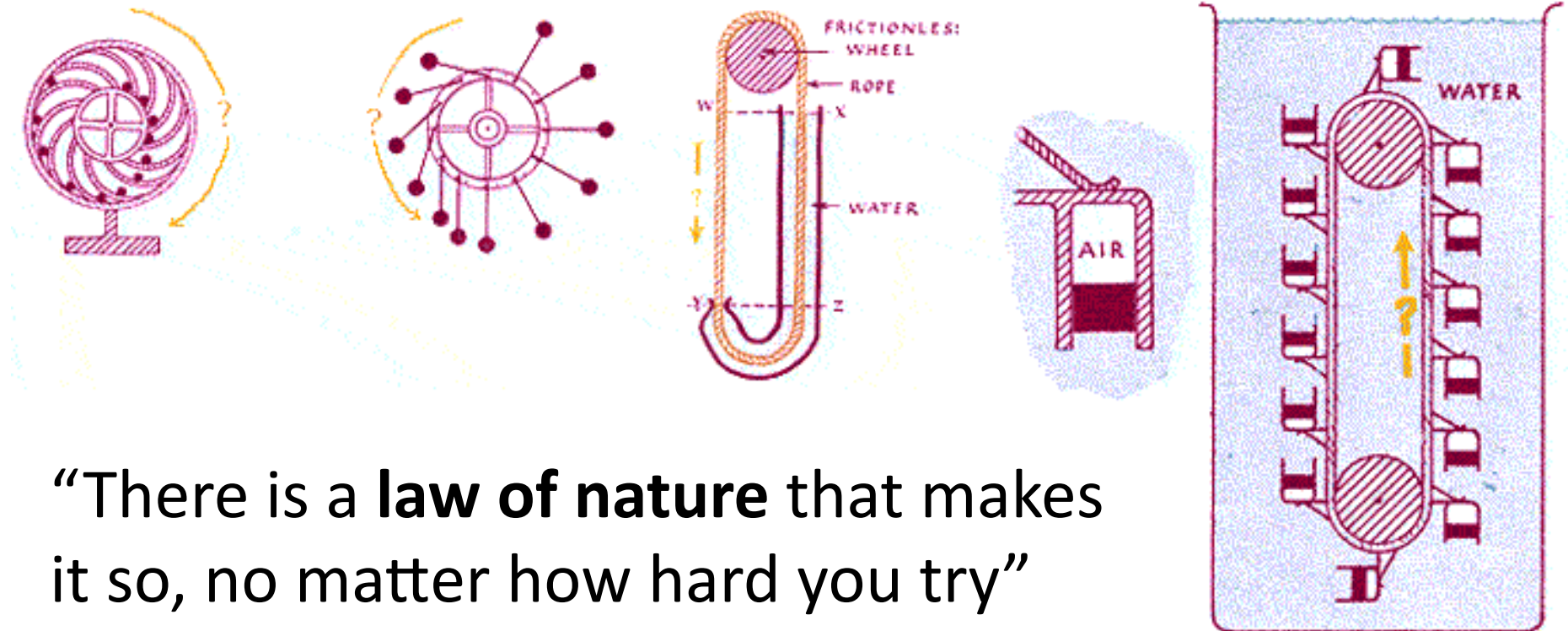

“There is a **law of nature** that makes it so, no matter how hard you try”

What is INsecurity?

- Holes for sneaking in executable code?
 - “Malicious code” has been deprecated for “malicious computation” (since 2000 by hackers, since 2007-8 by academia – a lesson of ROP)
- Memory corruption?
- In-band signaling?
- Exposing unnecessary privilege?
- All of the above?

Wikipedia on Causes of Vulnerabilities

- Complexity
- Familiarity
- Connectivity
- Password management flaws
- Fundamental OS flaws
- Internet Website Browsing
- Software bugs
- Unchecked user input
- Not learning from past mistakes

Vulnerability (computing)



Oh Fuck



Vulnerability classifications?

[In] a certain Chinese encyclopaedia ... the animals are divided into:

- (a) belonging to the emperor, (b) embalmed,
- (c) tame, (d) suckling pigs,
- (e) sirens, (f) fabulous, (g) stray dogs,
- (h) included in the present classification,
- (i) frenzied, (j) innumerable,
- (k) drawn with a very fine camelhair brush,
- (l) others, (m) having just broken the water pitcher, (n) that from a long way off look like flies.

--- *Jorge Luis Borges,*
“The Analytical Language of John Wilkins”

Nature and origins of insecurity:

Need a leap from “Lamarck” to “Watson and Crick”

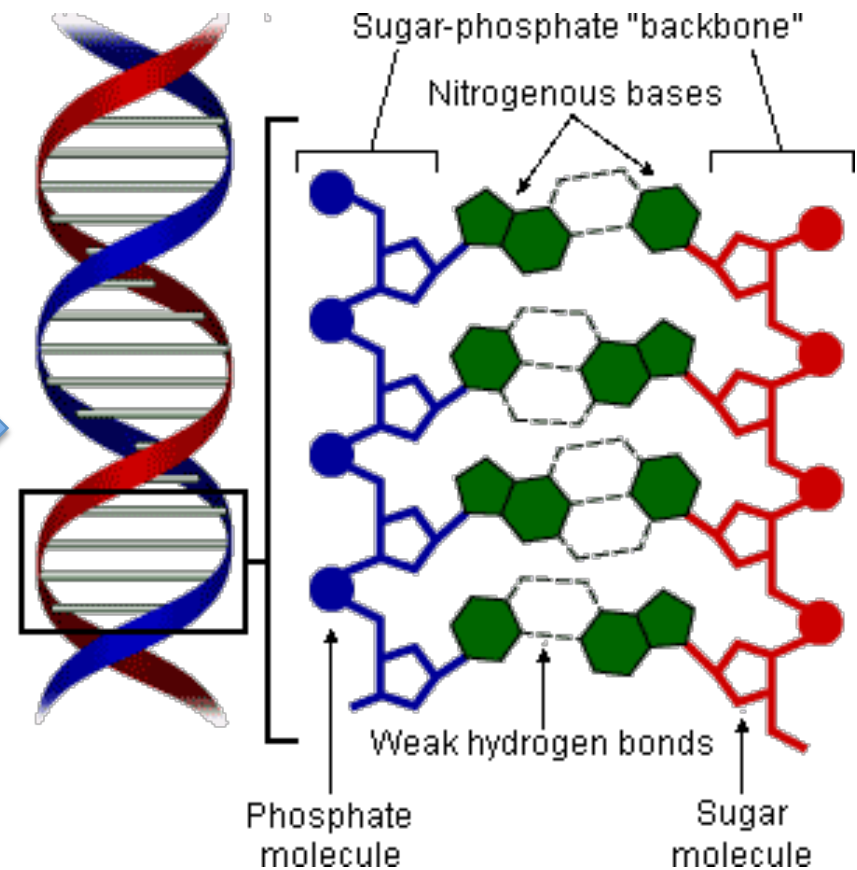
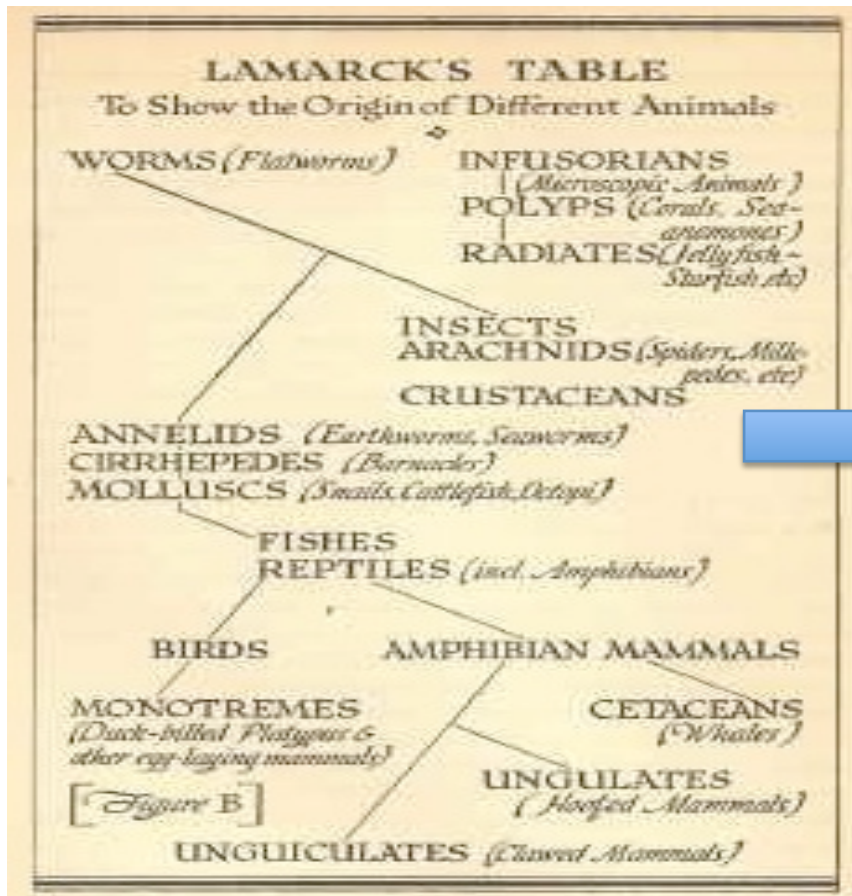

Insecurity is inseparable from **computation**

- *Trustworthiness* of a computer system is **what the system can and cannot compute**
 - Can the system decide if an input is invalid/unexpected/malicious & reject it?
 - Will program perform only *expected* computations, or *malicious* ones too?
- Computation has some **unsolvable** (undecidable) problems – about **recognition of inputs!**



Is insecurity due to program/protocol designs setting us up to solve **undecidable** problems? **YES!**

- Some designs force programmers to “solve” the **undecidable** Halting Problem w.r.t. **inputs** and **communications** (protocols, formats).
 - Bad news: no amount of **testing** or “**fixing**” helps
 - Good news: they can be avoided
- How did we get there and how to fix it?

Basic requirements in a composed world

- One component/program accepting inputs
 - Must accept or reject messages safely
- Components communicating (distributed system, layered architectures)
 - Messages must be interpreted identically by endpoints

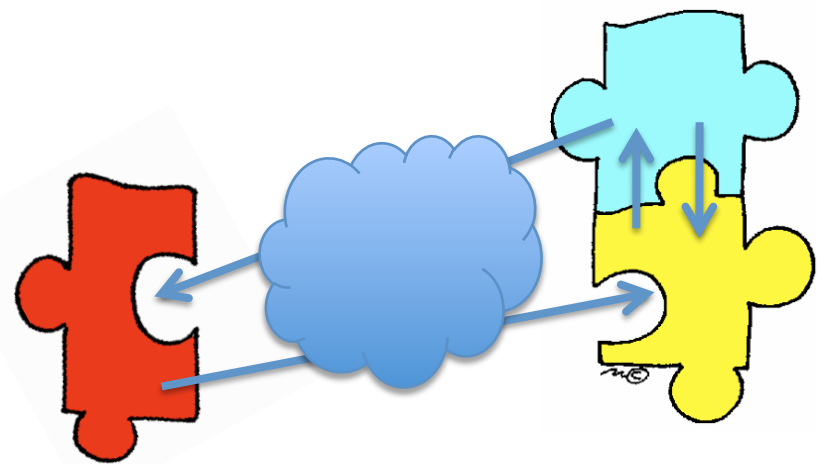
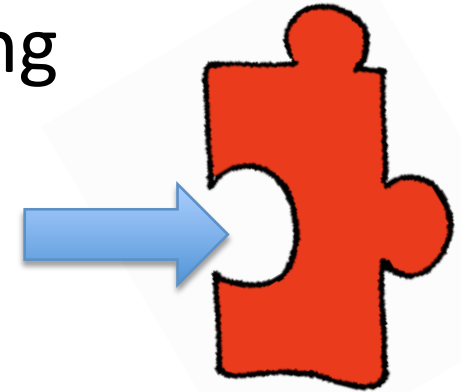

Undecidable Problems Attack!

- Some message/file formats are so complex that telling “good”/valid inputs from “bad”/invalid ones is **undecidable**
- Some protocols are so complex that checking whether different implementations handle them equivalently is **undecidable**

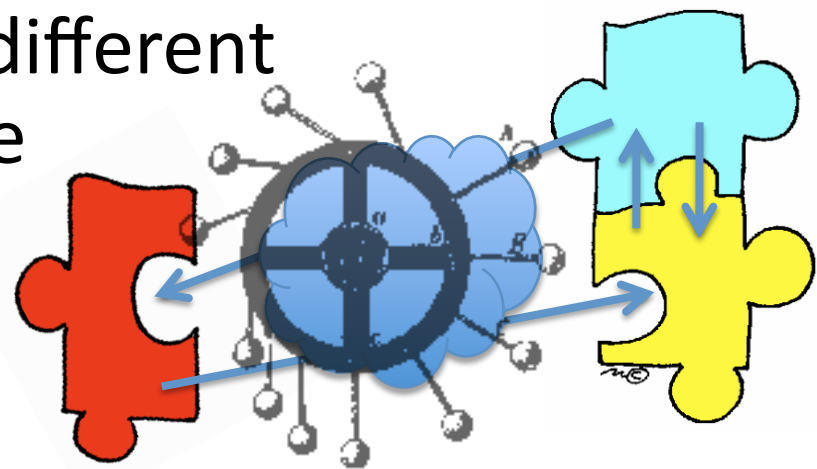
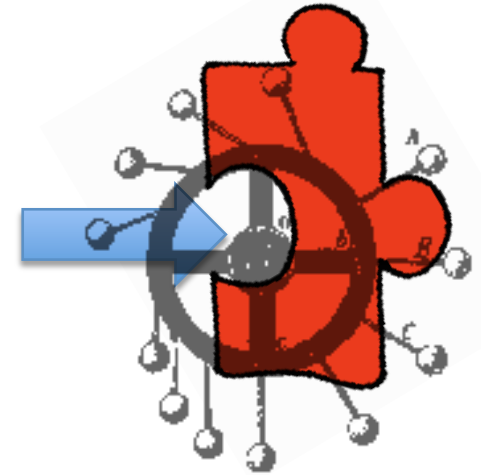

No 80/20 for the Halting Problem, same as for Perpetual Motion

- There is no “80/20” engineering solution
 - No amount of **testing** or “**fixing**” will help
 - If someone is selling it, run away --
you don’t want to be around when it breaks

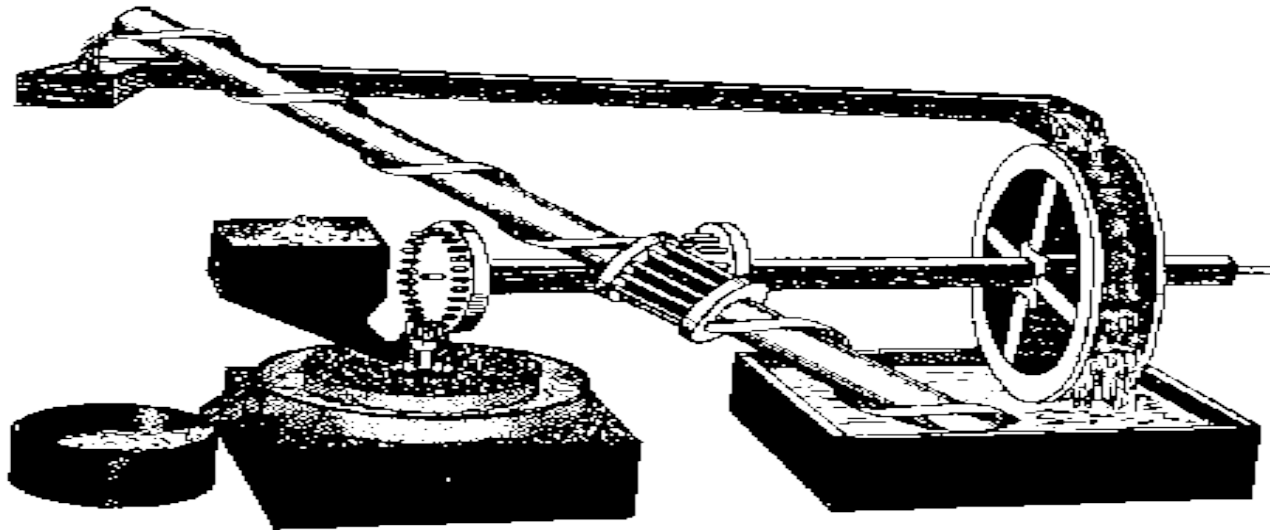

“The Hidden Recognizer”

- These are **language recognition problems**, so Turing/Church **MUST** be used to settle them
- The deadliest programming/design pattern:
The Scattered Recognizer (“*Shotgun parser*”)
 - Checks for input validity are scattered throughout the program, mixed with processing logic
- Implicitly/vaguely understood input languages:
the mother of all Halting Problems
 - We’ll show exactly how the Turing Beast arises

The Turing Beast



Back to the Turing Future to slay the Turing Beast!

- Insecurity as related to computation must be understood from the **Turing** and **Church** basics of computation – but with exploit programming lessons in mind
 - Academics study **models of computation**
 - Hackers study actual **computational limits of real systems**

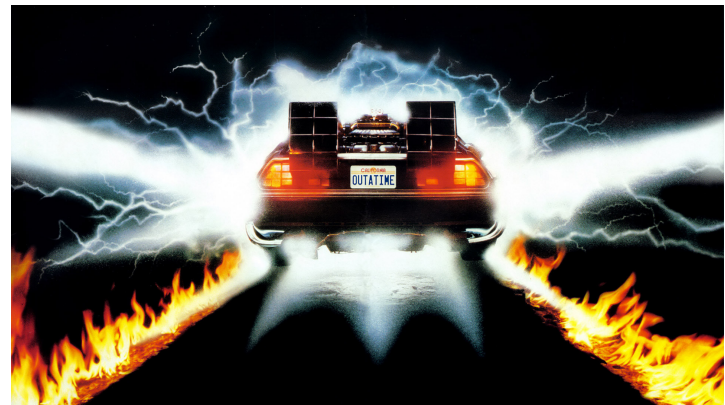

Turing machines and undecidability

Turing Machine: the model of computer to study the limits of what is **computable**

TM can do what your computer, phone, keyboard, NIC, ... can do

Undecidable problems:
No TM can solve them.

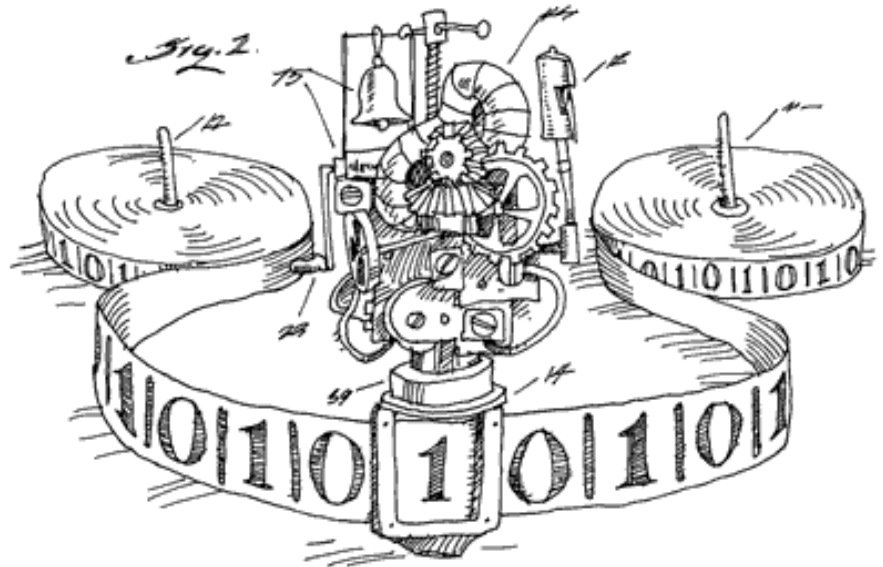

“The Halting Problem is Undecidable”

Cornerstone: the Halting Problem

- “I can build a TM that takes another TM as input and decides if it will ever terminate”

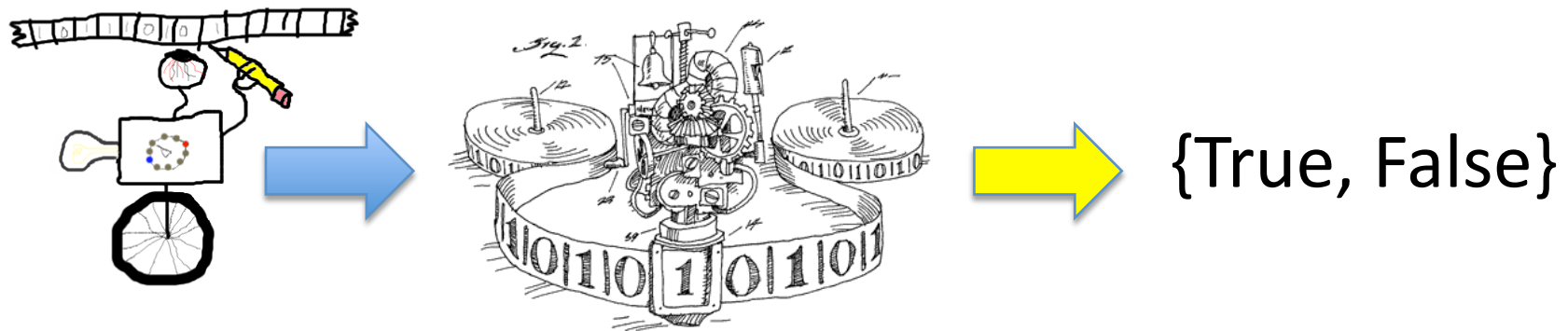

Cornerstone: the Halting Problem

- “I can build a TM that takes another TM as input and decides if it will ever terminate”

(EPIC FAIL)

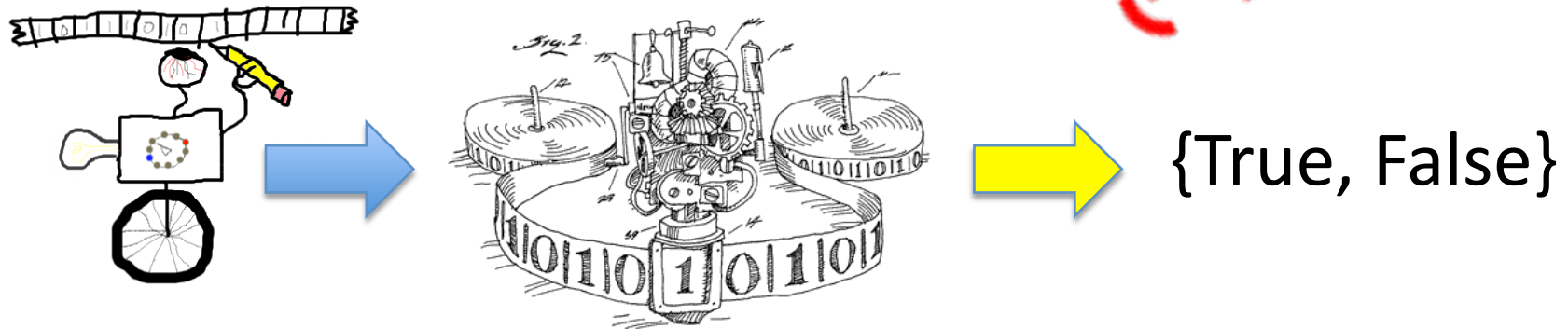

=



The history of the Uncomputable

- Leibniz: “*Can a machine determine truth values of mathematical statements*”? [17th century]
- Hilbert’s Entscheidungsproblem, [1928]
 - “*Is an arbitrary logical statement valid or invalid*”?
- Church [1936], Turing [1937]: **Negative!**
 - Based on work by Kleene, Goedel [1930s]
- Curry-Howard correspondence: programs are proofs and vice versa

Programs and exploits as proofs

- **Curry-Howard** correspondence: **programs** are **proofs** and vice versa
- **Exploits** are **proofs** too: by **construction** of unexpected/hostile computation
- Formal Duality? <TBD>

The right machine for a task ("mostly harmless")

- Matching regular expressions:
finite state machines

$a[ab]^+a \mid b[ab]^+b$

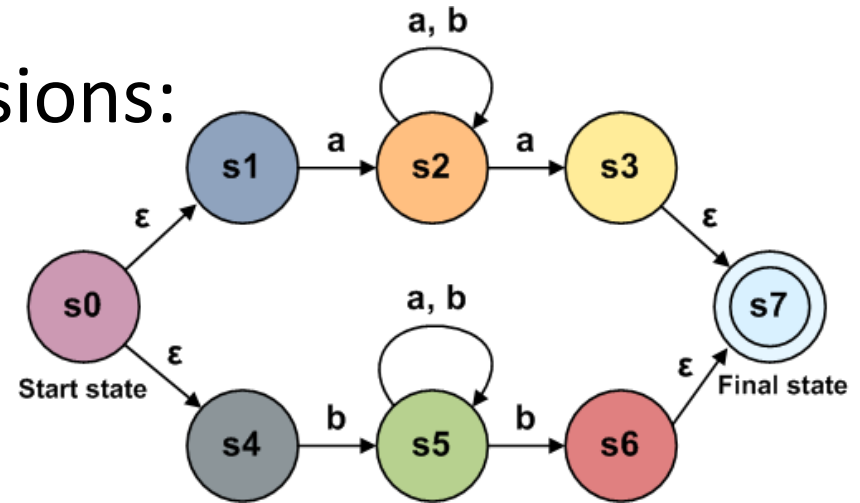

- Matching recursively nested structures:
pushdown automata

$((([({(\dots)}])))$

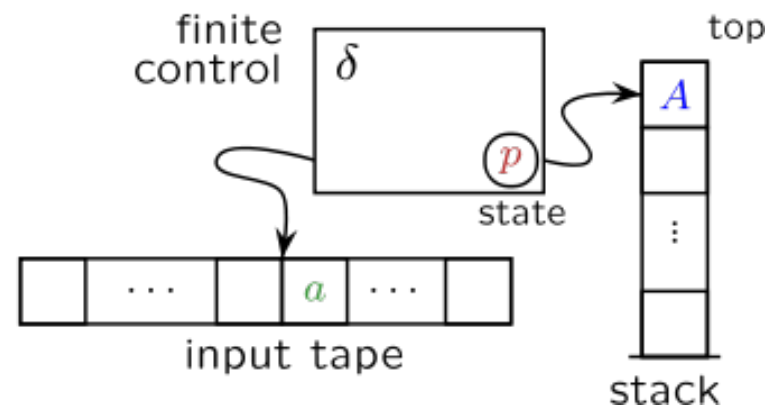

The right machine for a task (2)

- Telling data from metadata (“weakly context-sensitive” protocols, e.g., those with **length fields**)

Parsing an IP packet past a few corrupted bytes

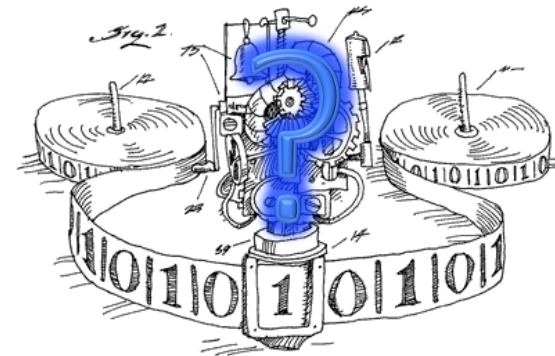

- Telling if input is a program that produces a given result:
UNDECIDABLE (Rice's Theorem)

FAIL

The language hierarchy

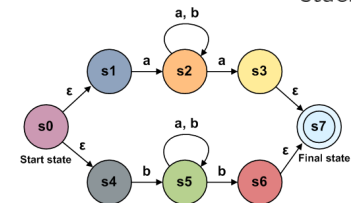
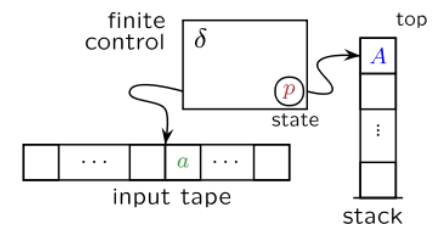
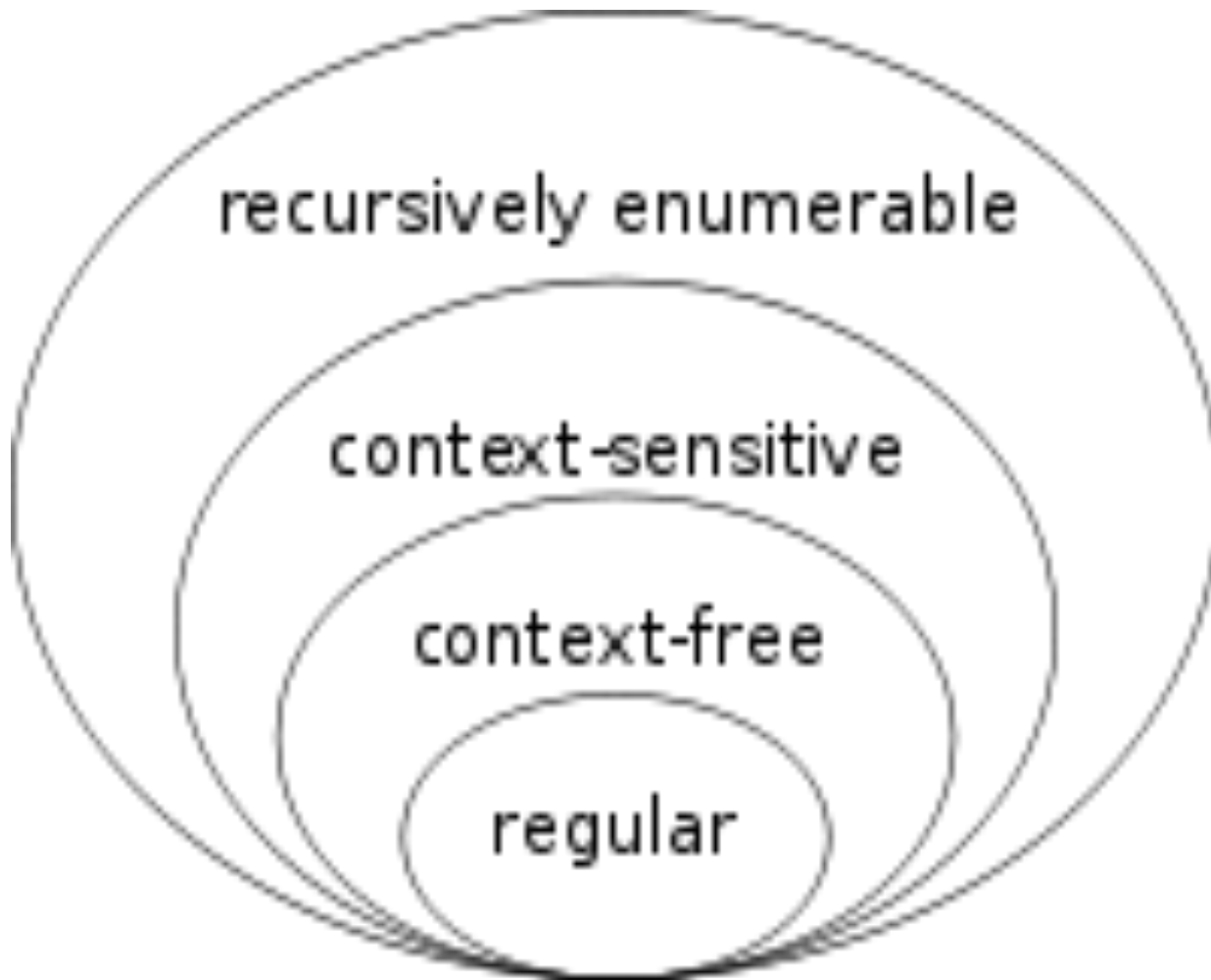

“Type I”: Input Handling

In-component, “The weird machine inside”

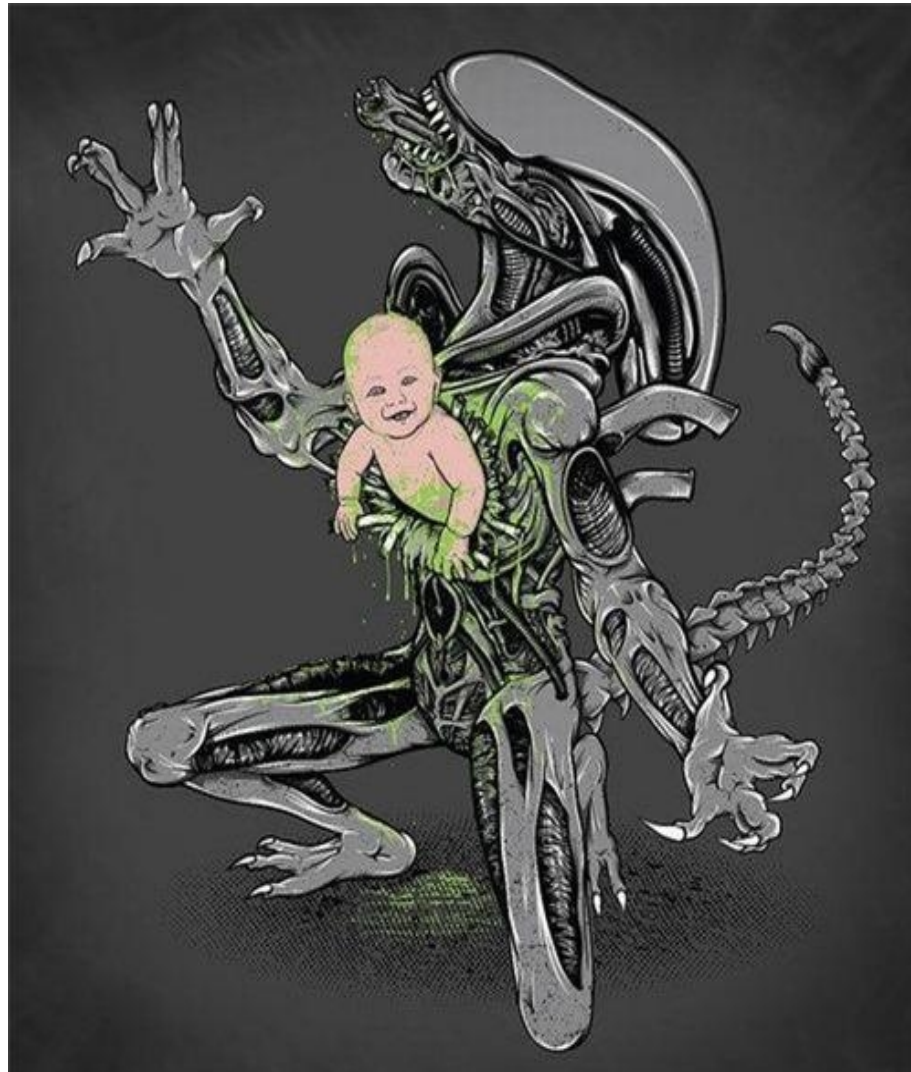

Insecurity: “What is exploitation?”

- Exploitation is unexpected computation

```
1119  sendmail: accepting connections
31337  \_ -bash
31338  \_ rm -rf /
```

- Exploits are **programs written in crafted inputs** that cause unexpected computation in the target system
- Programs for **what machines?** See Halvar Flake/Thomas Dullien talk @ Infiltrate 2011

“Weird Machines”

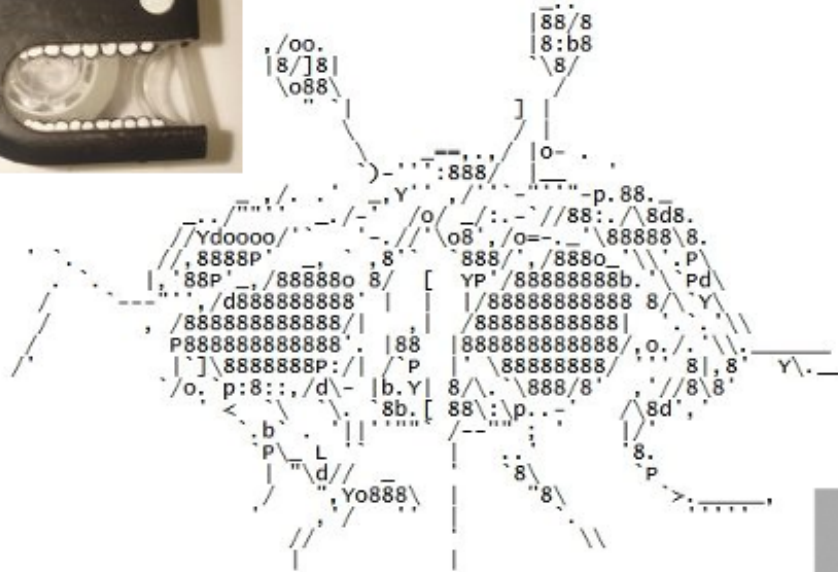

W W F S M O ?



***“Exploitation is setting up,
instantiating, and programming a
weird machine””***

- A part of the target is overwhelmed by crafted input and enters an **unexpected** but **manipulable** state
- A “weird machine” is unleashed
 - Who let the dogs out?
- **Inputs** drive unexpected computation



Inside every program are weird machines waiting to break out

- Wherever **input** is accepted and processed by **ad-hoc code**, bugs are likely
- “***Deviant inputs***” cause memory corruption, type misinterpretation (e.g., signed vs unsigned integer overflow), etc.
- “**Primitive**” corrupting inputs are combined into full exploit-programs
 - See gera, “***About Exploits Writing***”, 2002
 - Our upcoming article in **;login:** December 2011

“Bugs to primitives to exploits”

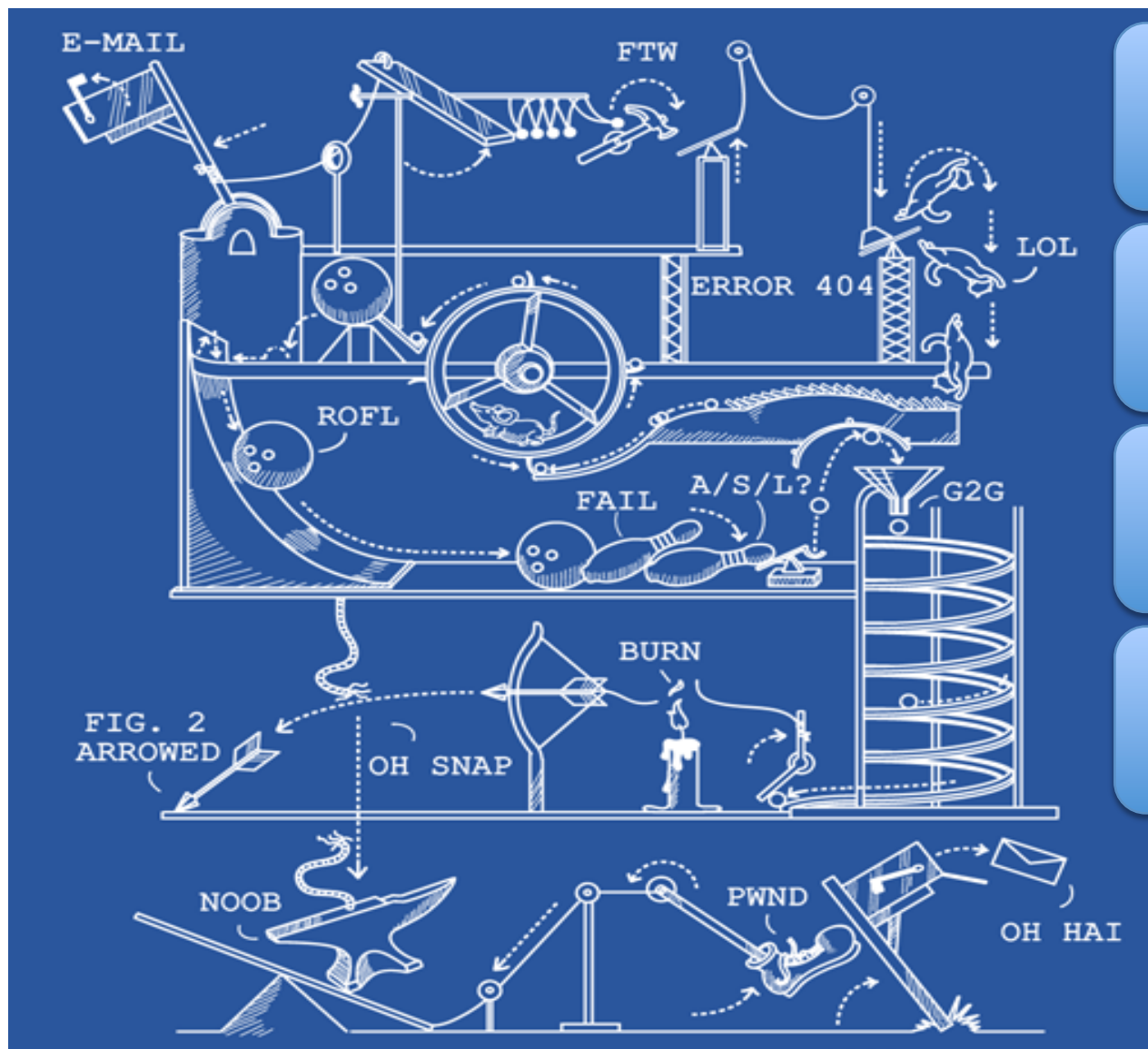

Phrack 57:8

Phrack 57:9

Phrack 58:4

Phrack 59:7

Phrack 61:6

“Bugs to primitives to exploits”

Phrack 57:8 MaXX, Vudo malloc tricks

Phrack 57:9 Once upon a free()

Phrack 58:4 Nergal, Advanced return-to-libc exploits

Phrack 59:7 riq & gera, Advances in format string exploitation

Phrack 61:6 jp, Advanced Doug Lea's malloc exploits

Occupy Input Handlers!



Is it **all** about parser bugs?

- No, but that's a large chunk of it
- Every program component that receives input from others has a **recognizer** for **the language of valid or expected inputs**
- If the **recognizer** does not match the **language**, it is broken
- If neither is well-defined or understood, the program is broken

Languages are everywhere!

- Network stacks: valid **packets** make a language
 - Stack is a recognizer at every layer/protocol
- Servers: valid **requests** make a language
 - e.g. SQL injection is a recognizer failure
- Memory managers: **heaps** make a language
 - Heap metadata exploits abuse its context-sensitivity
- Function call flow: valid **stacks** make a language
 - Context-sensitivity again, which bytes are data, which are metadata?

An **implicit** recognizer is a **bad** recognizer

- **Ad-hoc** recognizer logic scattered throughout the program is **hard** to **test** and **debug**
- Lots of intermixed recognition/processing state => lots of **unexpected states**, data flows, and **transitions** (hello “weird machine”!)
 - Weird machines run on borrowed state
 - (cf. Halvar’s Infiltrate 2011 talk)
- Don’t process what you cannot first recognize!

Occupy Program State!

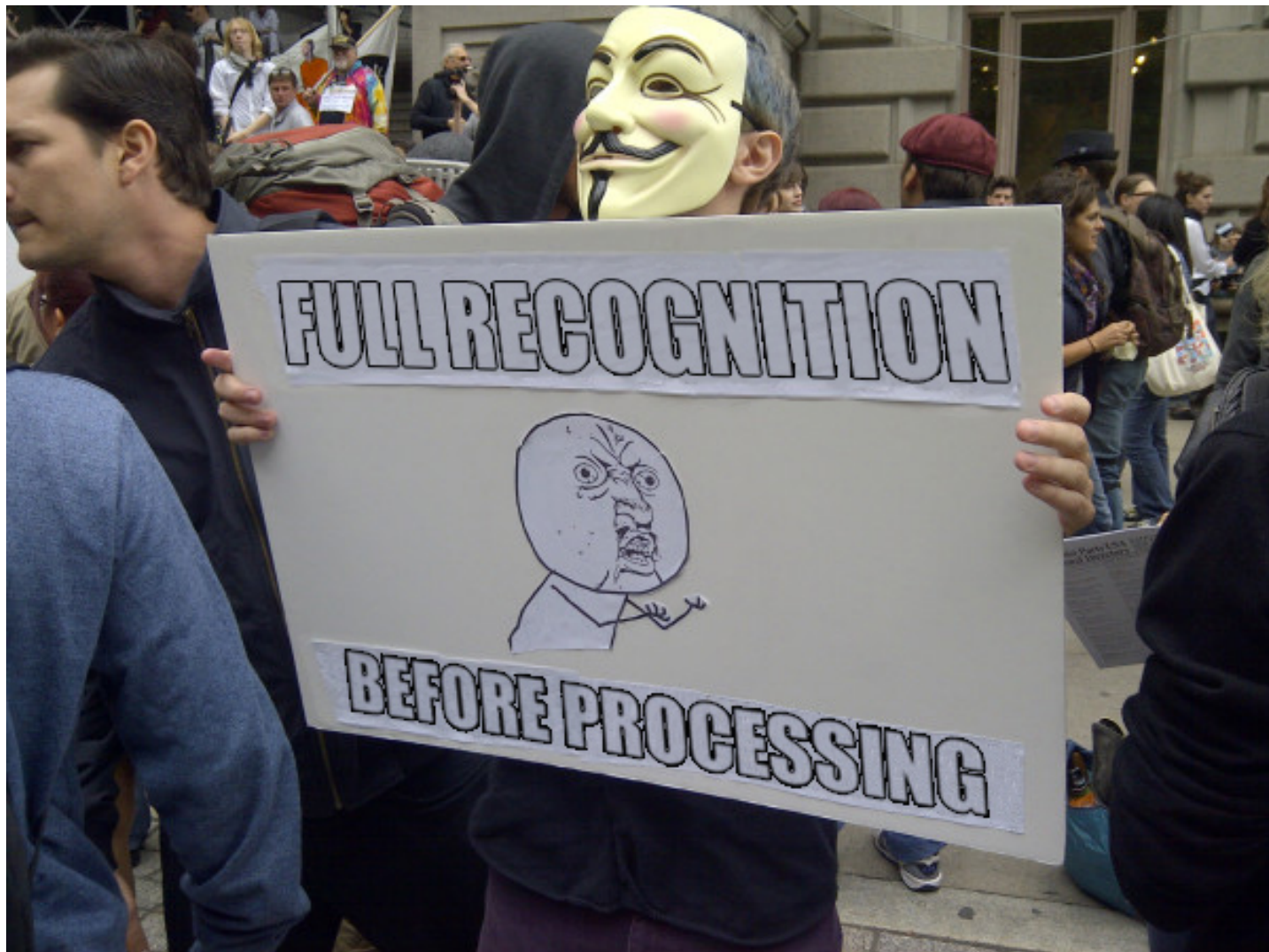

Regard all valid/expected inputs as a formal language

- **Know** and **be strict about** what your input language is
- Know what computational power it requires to get recognized
 - **Never** parse **nested structures** with **regexps!**
- Write the recognizer explicitly or, better, **generate** it from a **grammar**
- Stay away from Turing-complete input languages

Occupy Message Formats!



“Regular is a safe place to be”

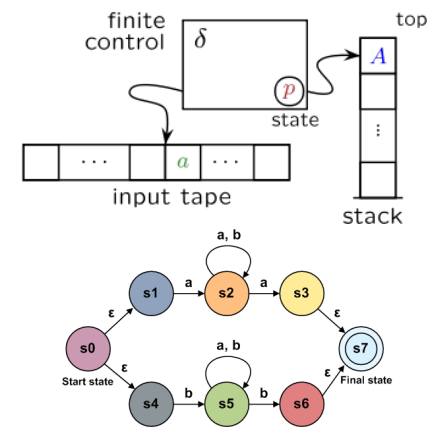
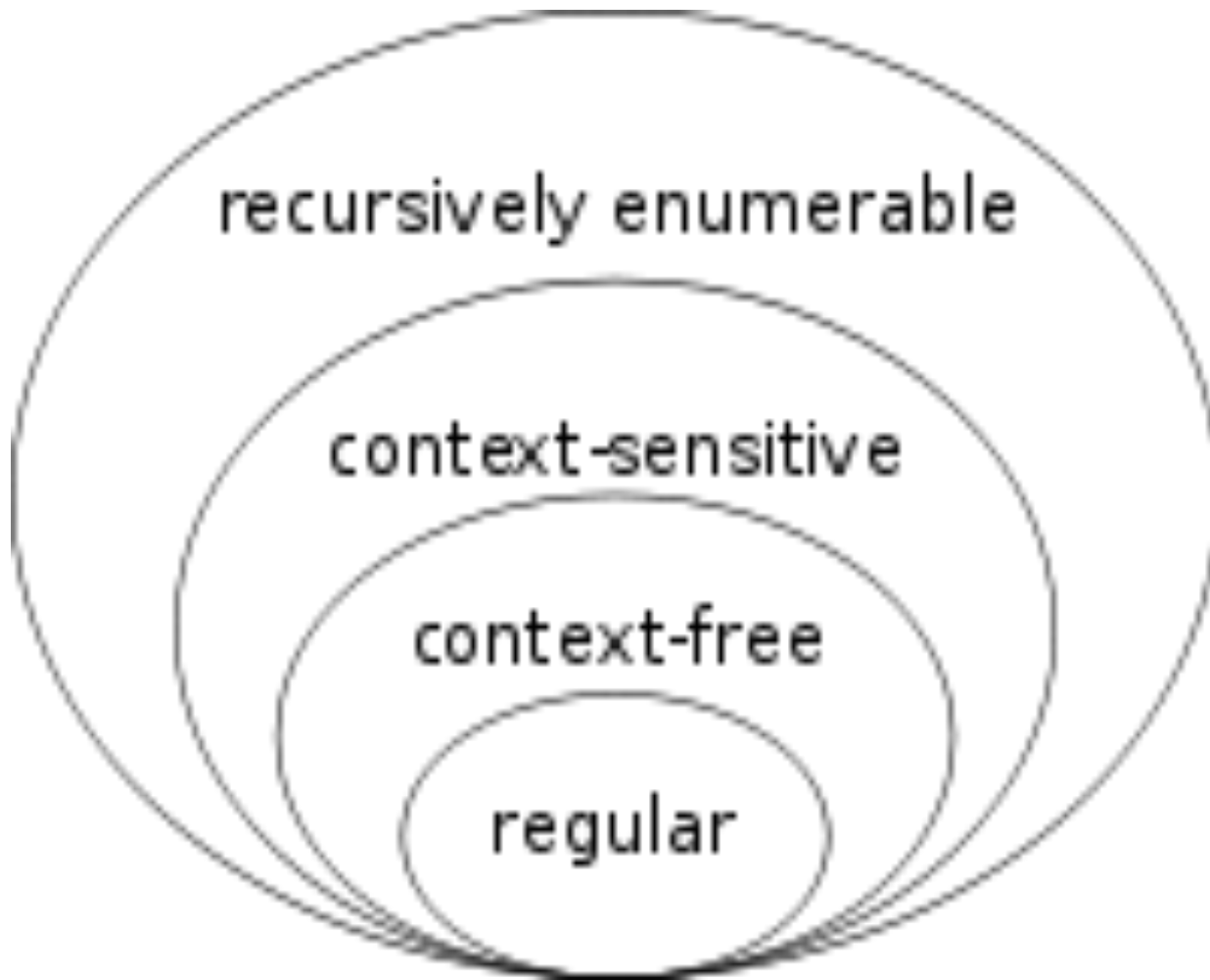

Occupy Protocol Design!



II. Composition & communication

Computational equivalence
between components:

“Are you seeing
what I’m seeing?”

12
ABC
14



Insecurity: miscommunication

- Today's systems are distributed/composed, with many talking components

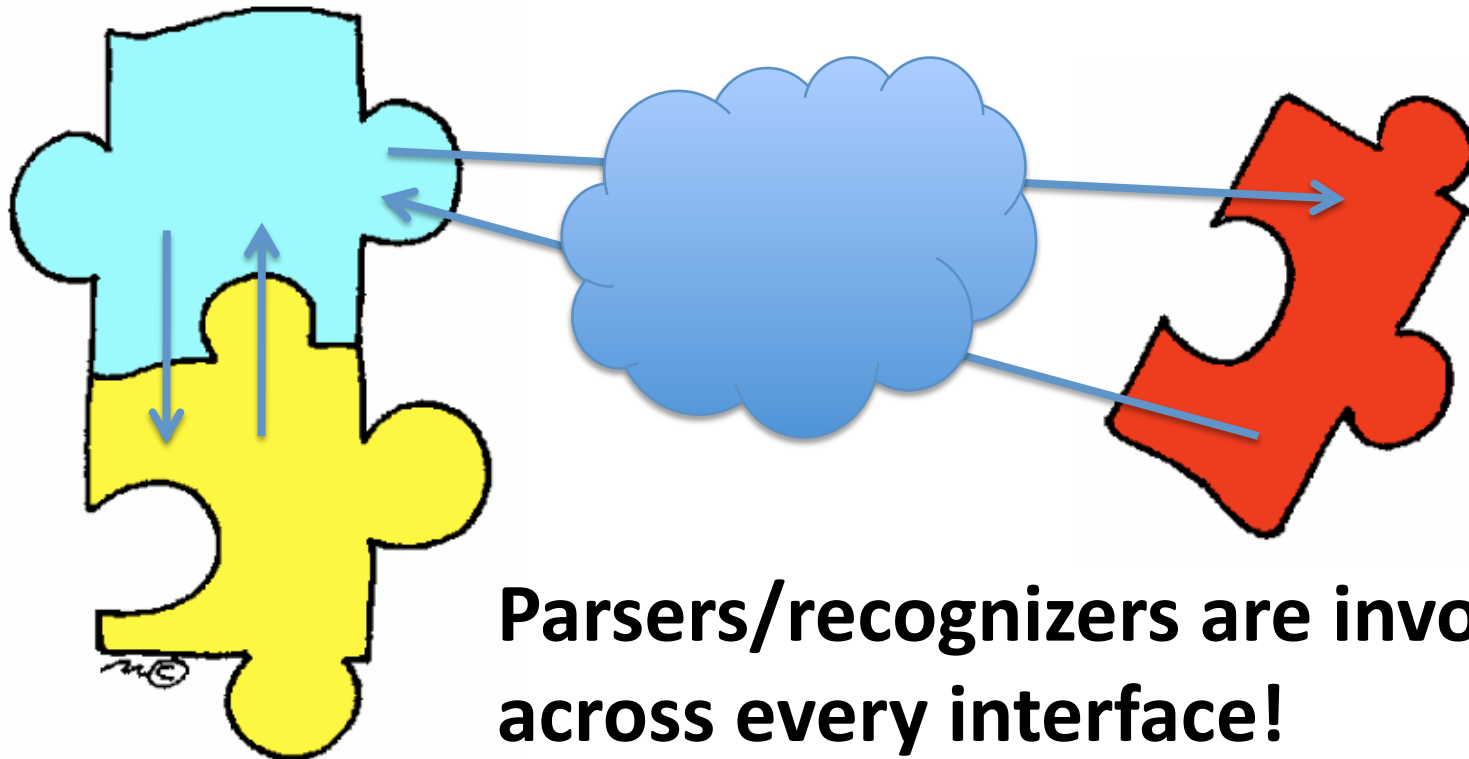

Parsers/recognizers are involved across every interface!

Parser computational equivalence

- Parsers involved in a protocol/exchange must parse messages **exactly the same way**
 - For X.509 SSL certs between CA and browser, **formally** required
 - Between a NIDS and its protected target, **effectively** required
- Equivalence must be assured/**tested**
 - with automation tools, unit tests, integration tests

The X.509 Case Study

- X.509's Common Names (CN) :
an **ambiguous** language, **ad-hoc parsers** =>
 - Certificate Signing Request (CSR) parsed differently by the signing CA and certificate consumer (e.g., browser) =>
 - Browser believes the CA signed this cert for google.com, ebay.com, paypal.com, ...
- 20+ 0-day from Parser Differential Analysis
 - Sassaman, Patterson “Exploiting Forest with Trees”
 - ASN.1 BER ambiguous, considered harmful

Halting Problem, hello again

- Testing computational equivalence for two automata recognizing **regular** languages (regular expressions) and **deterministic pushdown** automata is **decidable**
 - Tools/software automation can help
- **But for non-deterministic pushdown automata or stronger it is UNDECIDABLE**
 - No amount of automated testing effort will give reasonable coverage

The curious case of the **IDS**: moving the Halting Problem around

- Trying to “fix” **Input Recognition** Halting Problem of a scattered and vaguely defined recognizer with another, “less vulnerable” component?
 - But it can’t be fixed! So a “fix” **must** backfire.
- So you get the **Endpoint Computational Equivalence** Halting Problem between the IDS’ stack and the target’s input protocol handling!

“Insertion, Deletion, Evasion” & other horsemen of the IDS/IPS Apocalypse

- Ptacek & Newsham, 1998
- Vern Paxson, 1999--...

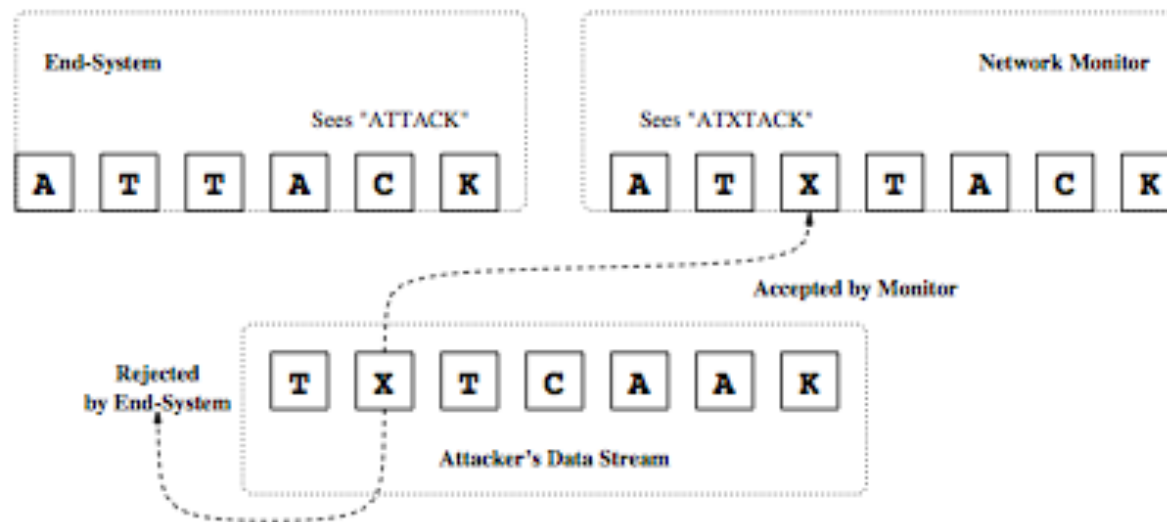

Figure 4: Insertion of the letter 'X'

“Conservation of (bad) computational power”

- Computational power once created cannot be destroyed
- “Dark energy” of scattered parsers will resurface
- You have not fixed the Halting Problem due to input language complexity, you just converted it into another Halting Problem

Stay away from the Halting Problem

- Choose the **simplest possible** input language, preferably **regular** or at most **deterministic context-free**

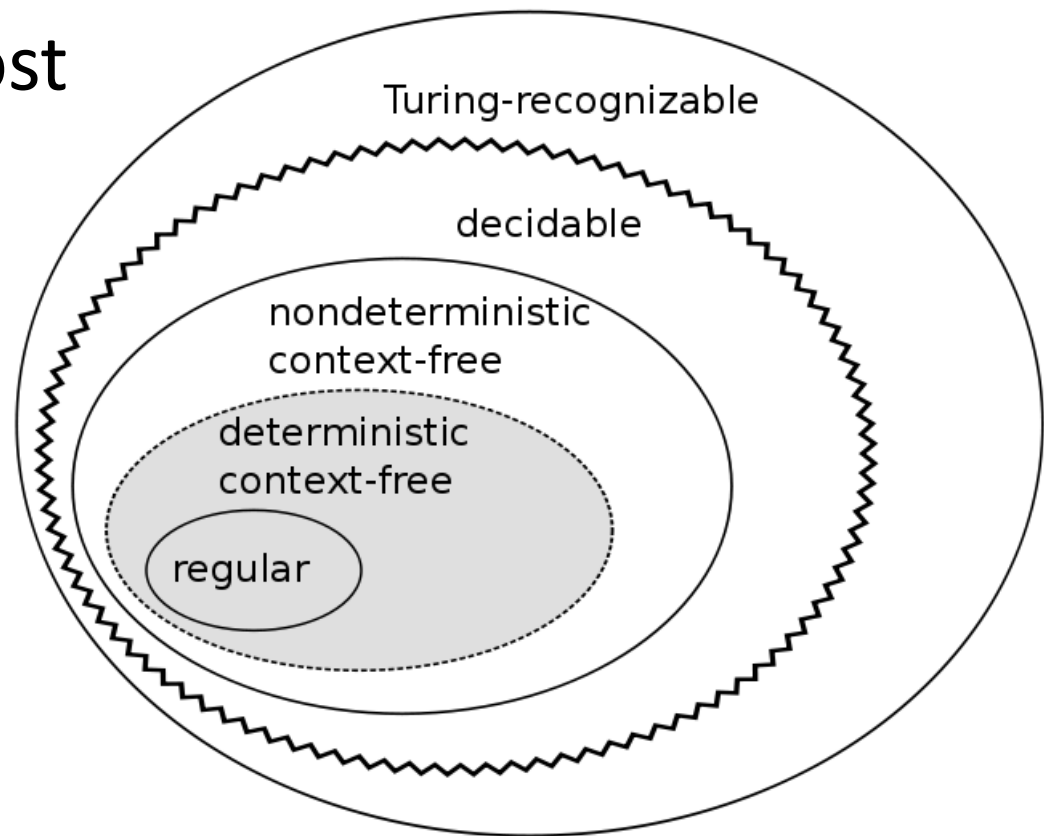

Occupy the IETF!



Time to re-evaluate Postel's Principle?

*“Be conservative in what you send;
be liberal in what you accept.”*

- it made the Internets happen and work
- its misreadings made the Internets
the way they are now

Postel's Principle needs a patch:

- Sassaman & Patterson, PhNeutral, March 2010
- Dan Geer, “Vulnerable Compliance” ;login:
December 2010 (free online)

The Postel's Principle Patch

- Be liberal about what you accept
- + Be **definite** about what you accept
- +
 - + Treat inputs as a language, accept it with a
 - + matching computational automaton, generate its
 - + recognizer from its grammar.
- +
 - + Treat input-handling computational power as privilege,
 - + and reduce it whenever possible.

Take-away?

- Good protocol designers don't allow their protocols to grow up to be Turing-complete
- Ambiguity is Insecurity!
- If your application relies on a Turing-complete protocol, it will take infinite time to secure it
- Rethink Postel's Law

Money talks

Language-theoretic approach helps to

1. save mis-investment of money and effort,
2. expose vendors that claim security based on solving perpetual motion,
3. pick the right components and protocols to have manageable security,
4. avoid system aggregation/integration nightmare scenarios.

Do not mistake complexity for functionality

- Saving money on future upgrades thanks to Turing-complete "extensibility"?

See that you are not going to lose more on security/mediation/controls, eaten up by the Turing Beast.

- "This system is very extendable/updatable because it embeds macros/scripting/programming language in data" -- run like hell

Occupy Input Handling!

- “Stop Weird Machines”
- “No More Turing-complete Input Languages!”
- “Reduce Computing Power Greed!”
- “Ambiguity is Insecurity!”
- “Full recognition before processing!”
- “Computational equivalence for all protocol endpoints!”
- “Context-free or Regular!”

Thank you!

<http://langsec.org>

<http://langsec.org/occupy/>